



YUNCA
HEATING

A division of Terry Young Ltd.



JANUARY 1997 (Revised October 2010)
INSTALLATION INSTRUCTIONS FOR THE ORIGINAL YUNCA
MULTI-FUEL FREESTANDING BURNER

(NO LONGER IN PRODUCTION – referred to as the “new model” multi
in our spare parts guide)

TESTED TO NZS 7421-1990

- A. Yunca recommends that competent trades persons carry out all installations (e.g. NZHHA registered installer) to obtain maximum performance and safe, efficient heating.
- B. A permit is required and we suggest you check with your local building inspectors as by-laws can vary from area to area. This model is not clean air approved. Also notify your Insurance Company that a space heater has been installed.
- C. Floor Protector
 - 1. Must extend at least 300mm in front of closed door.
 - 2. Must extend at least 150mm on each side of heater.
 - 3. Spill hearth must be constructed of non-combustible material, with a minimum thickness of 50mm.
- D. Seismic restraint
Heater must be restrained from seismic movement as required by AS/NZS 2918:2001.
- E. Manufacturers recommended minimum clearances from combustible walls.

APPLIED RESEARCH tested to NZS 7421-1990	Clearance (FIG D)
Rear Clearance (with YUNCA flue guard fitted)	200mm
Side Clearance (with YUNCA flue guard fitted)	700mm
Corner Clearance (with YUNCA flue guard fitted)	200mm
Rear Clearance (without YUNCA flue guard fitted)	700mm
Side Clearance (without YUNCA flue guard fitted)	800mm
Corner Clearance (without YUNCA flue guard fitted)	200mm
Minimum Hearth clearance (from door aperture)	300mm

- F. **YUNCA Flue Kit** (complies to AS/NZS 2918:2001, Appendix F): **FIG A, B, E**
 - 1. 4.2m x 150mm stainless steel flue.
 - 2. 2.4m x 250mm galvanised liner.
 - 3. 1 x ceiling tile.
 - 4. 1 x insulation boundary shield.
 - 5. 2 x spider brackets.
 - 6. 1 x weather cap & cowl.

Please Note: All joints must be sealed with flue sealing compound. Use stainless steel screws or rivets to join the flue pipe (three equally spaced places at each joint). The first length of flue pipe must be screwed to flue spigot. The required minimum flue termination height is 4.6 m above the floor protector.

- G. **Flue Mounted Shield (Flue Guard) Kit: FIG A**
 - 1. 1 x 1200mm length back guard plus a 900mm adjustable extension.
 - 2. 1 x 1200mm length perforated front guard

FIG A: TYPICAL FLUE INSTALLATION

600mm ABOVE RIDGE LINE (MIN)

FIG B

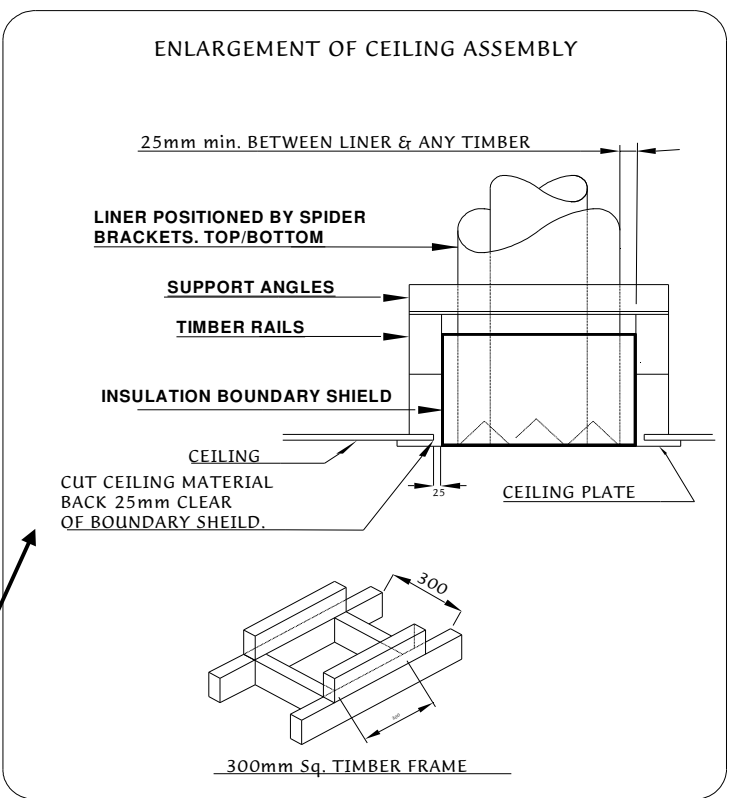
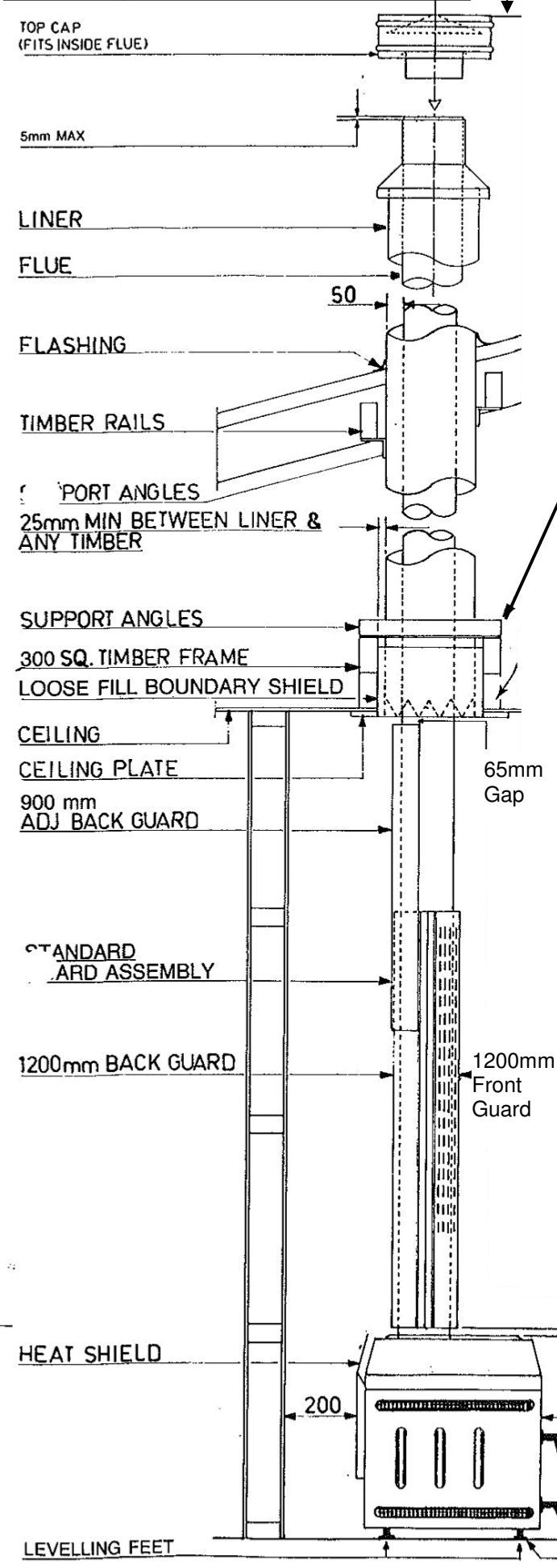

- CONDITIONS FOR FLUES**
1. The FLUE shall extend to:
 Not less than 600mm above the highest point on the roof if within 3.0m of that point, or
 Not less than 1000mm above the intersection point with the roof and not lower than any point of the roof within 3.0m.
 In any case the length of the flue shall not be less than 4.6m from the ash floor protector.
 In some situations the Local Council may vary the above requirements.
 2. The flue system must be tested and comply with AS/NZS2918:2001, Appendix F.
 3. The insulation boundary shield shall be capable of preventing accidental migration of loose-fill or any combustible material by any action of wind or by persons moving in the ceiling space.

FIG C: DIMENSIONS

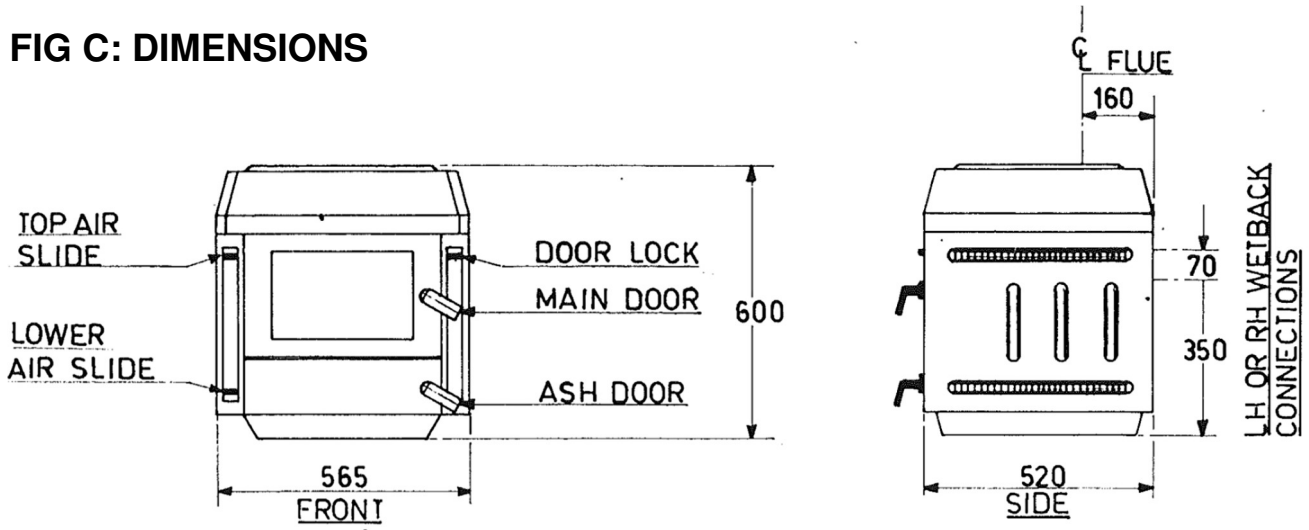

FIG D: HEATER POSITIONS

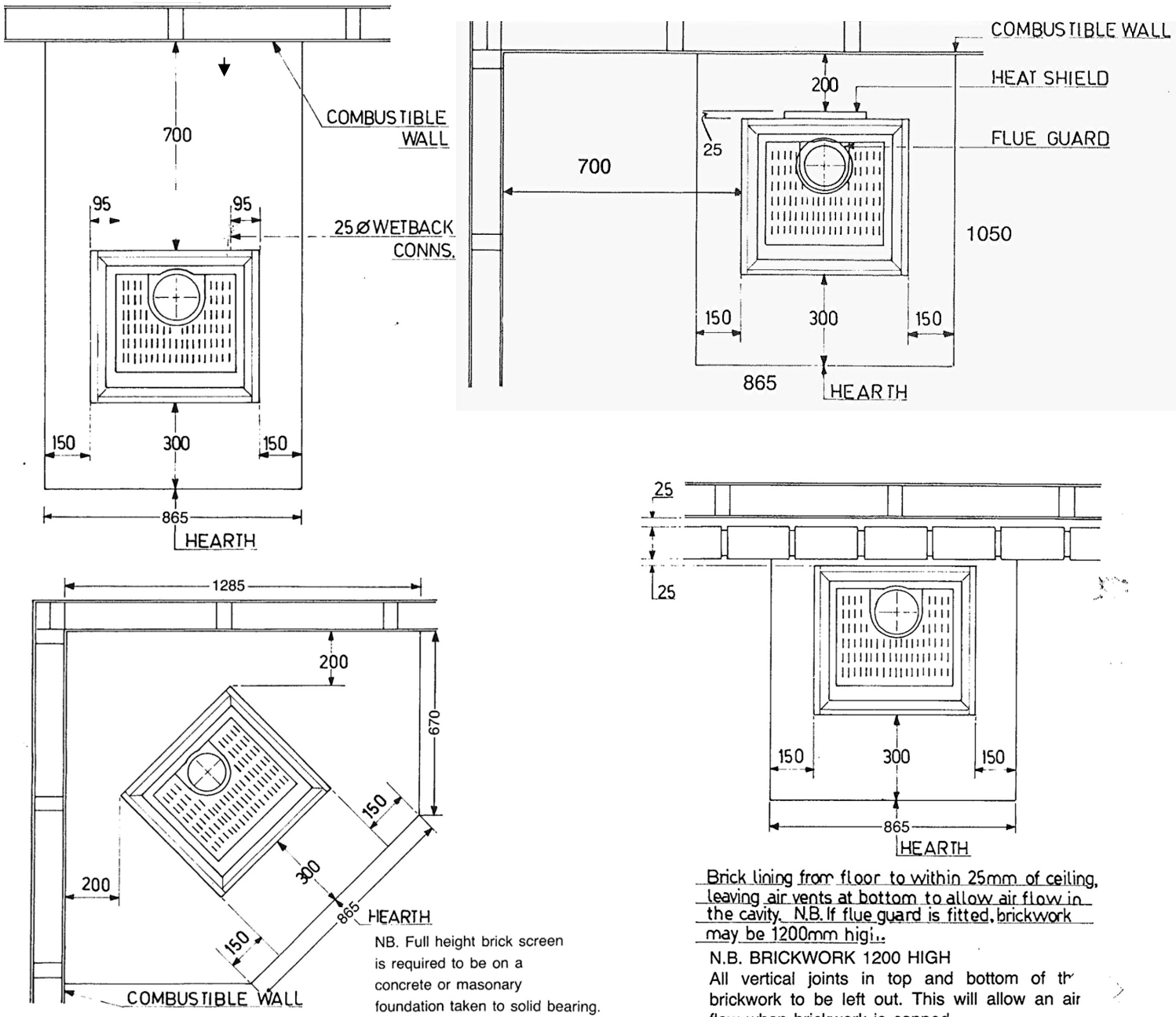
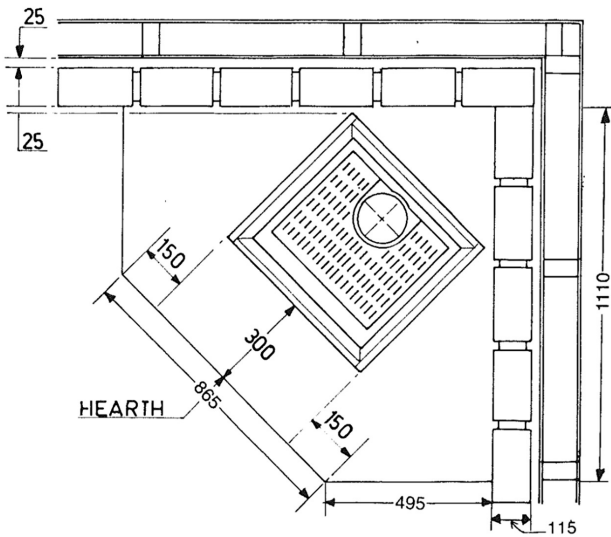

Fig D drawings continued on Page 4.

FIG D: Continued.



IMPORTANT

IF A WATERBOOSTER IS FITTED:

- A. Do not connect to an unvented hot water system
- B. Install in accordance with AS 3500.4.1 or NZS 4603 and the appropriate requirements of the relevant building codes.

IMPORTANT INFORMATION

- A. The appliance and flue system shall be installed in compliance with AS/NZS 2918:2001 and the appropriate requirements of the relevant building code or codes.
- B. Appliances installed in accordance with this standard shall comply with the requirements of AS/NZS 4013 where required by the regulatory authority i.e. the appliance shall be identifiable by a compliance plate with the marking "TESTED TO AS/NZS 4013"
- C. Any modification of the appliance that has not been approved in writing by the testing authority is considered to be in breach of the approval granted for compliance with AS/NZS 4013
- D. Mixing of appliance or flue system components from different sources or modifying the dimensional specification of components may result in hazardous conditions. Where such action is considered, the manufacturer should be consulted in the first instance.
- E. Cracked and broken components e.g. glass panels or fire bricks, may render the installation unsafe.
- F. Secure the heater base to the hearth or sub-framing with Dynabolts or similar. Seismic restraint brackets are available from Yunca Heating.

Follow local Council's Specifications – the Yunca Multi is NOT clean-air approved.

FIG E: FLUE SYSTEMS REQUIREMENTS

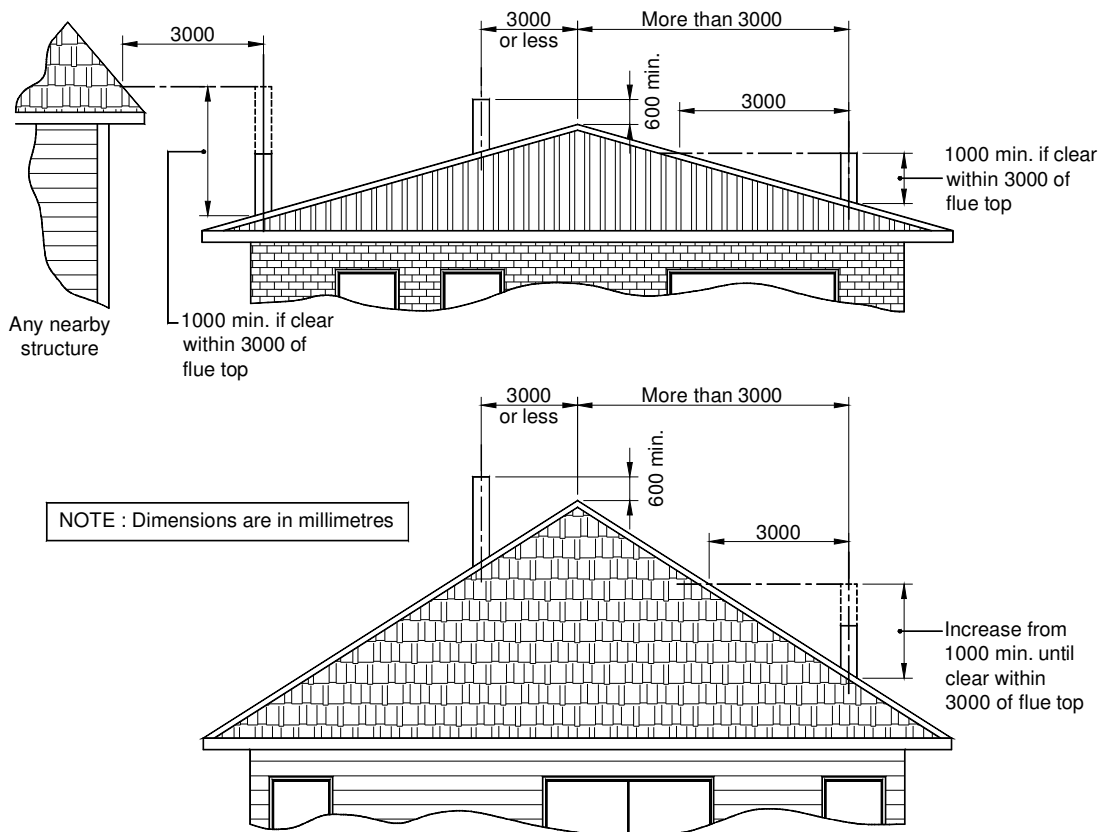

NOTE : Dimensions are in millimetres

MINIMUM HEIGHT OF FLUE SYSTEM EXIT