



A division of Terry Young Ltd , New Zealand

INSTALLATION INSTRUCTIONS for FITZROY (Sub 1.0) FREESTANDING WOODBURNER NOVEMBER 2010

TESTED in compliance with AS/NZS 2918: 2001

- A.** Yunca recommends that competent trades persons carry out all installations (e.g. NZHHA Registered Installer), to obtain maximum performance and safe, efficient heating.
- B.** A permit is required and we suggest you check with local building inspectors as by-laws do vary from area to area.
Also notify your Insurance Company that a solid fuel heater has been installed.
- C.** Floor Protector –
1. Must extend a minimum of 300mm in front of the door aperture.
 2. Must extend at least 100mm from each side of the heater.
 3. Ash Floor Protector must be constructed of non-combustible materials, with a minimum thickness of 12mm
- D.** Seismic restraint – Heater must be restrained from seismic movement as required by AS/NZS 2918:2001. 10mm diameter bolting holes in the feet of the FITZROY allow restraint.
- E.** Manufacturers' recommended tested minimum clearances from combustible walls:

Tested to AS/NZS 2918 : 2001 by APPLIED RESEARCH SERVICES	Clearance
Rear Clearance – <u>from rear of top lip</u> (with YUNCA flue mounted shield fitted) - N.B. clearance from rear <u>panel</u> is 120mm	100 mm
Side Clearance (with YUNCA flue mounted shield fitted)	300 mm
Corner Clearance (with YUNCA flue mounted shield fitted)	130 mm

F. YUNCA Flue Kit (Tested to AS/NZS 2918:2001 Appendix F): Fig A, B & E

1. 4.2m x 150mm stainless steel flue
2. 2.4m x 250mm galvanised liner.
3. 1 x ceiling tile.
4. 1 x insulation boundary shield.
5. 2 x spider brackets.
6. 1 x weather cap & cowl.

Please Note: All flue joints must be sealed with flue sealing compound. Use stainless steel screws or rivets to join the flue pipe (three equally spaced places at each joint). The first length of flue pipe must be screwed to flue spigot. The required minimum flue termination height is 4.6 m above the floor protector.

G. FITZROY Sub 1.0 Flue Mounted Shield (Flue Guard) Kit.

Complies (with heater) to AS/NZS 2918:2001: Refer Fig A.

- 1 x 1200mm length lined back guard plus an adjustable 900mm extension.
- 1 x 1200mm length perforated front guard
- 1 x 1200mm length tertiary back guard with spacer tabs.
- 1 x Top front deflector shield (half round shape, angled 30 degrees when installed).

Please Note: The minimum Flue Mounted Shield height is 1200mm.

FITZROY SUB 1.0 – TYPICAL INSTALLATION (not drawn to scale)

FIG A (below, left): FITZROY Sub 1.0 Flue Mounted Shield (Flue Guard) Kit. Complies (with heater) to AS/NZS 2918:2001

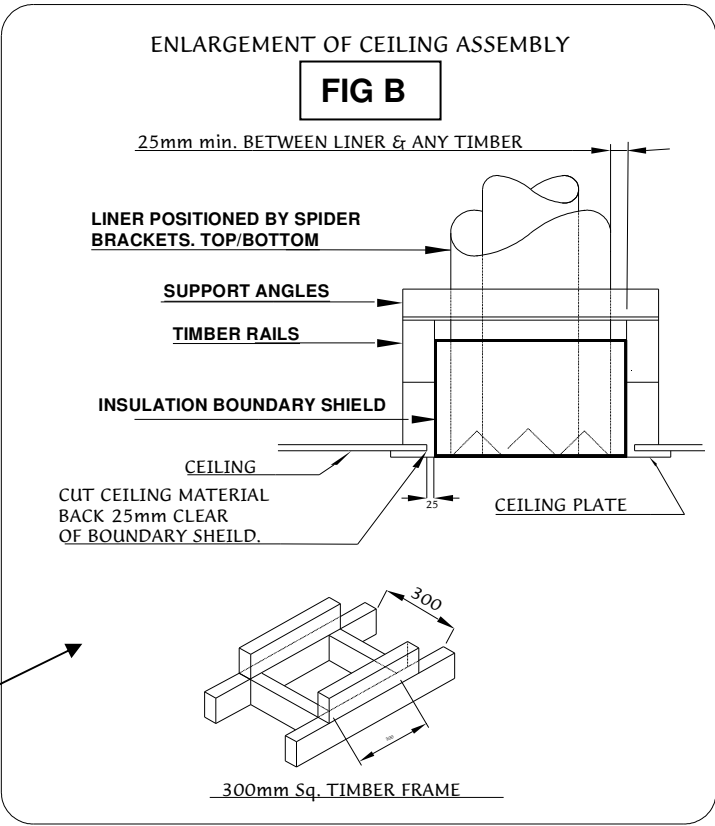
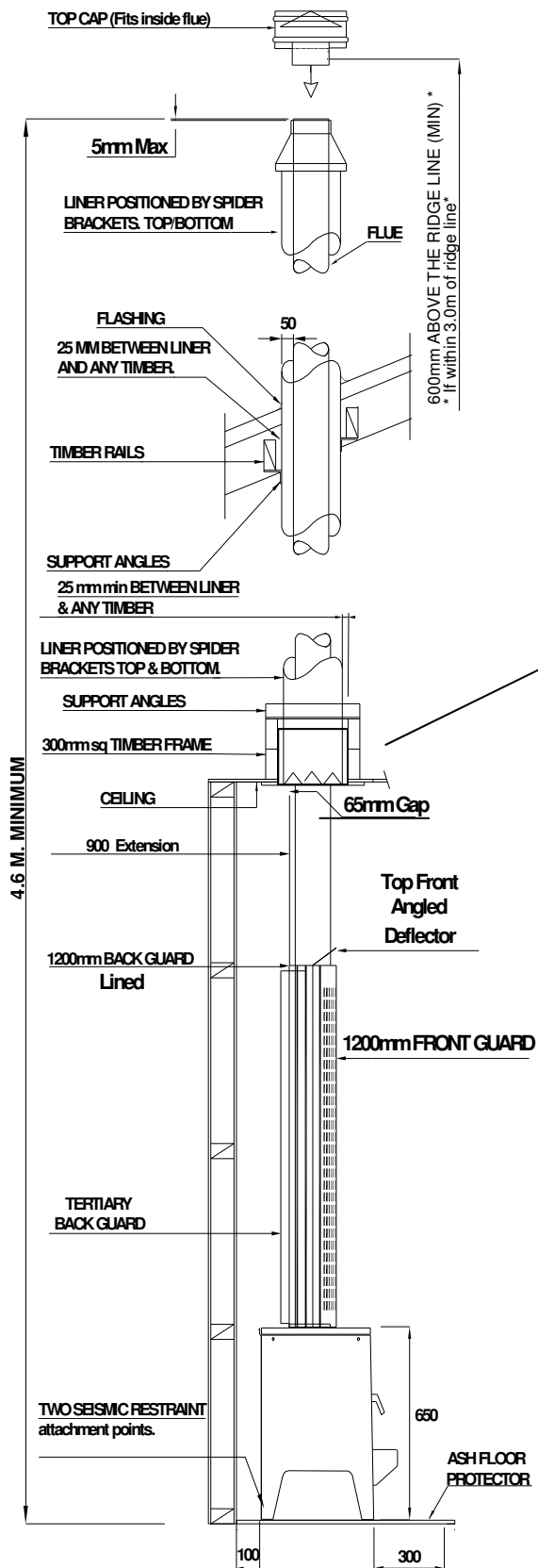

CONDITIONS FOR FLUES (Refer Fig. E)

1. The FLUE shall extend to:
 Not less than 600mm above the highest point on the roof if within 3.0m of that point, or
 Not less than 1000mm above the intersection point with the roof and not lower than any point of the roof within 3.0m.
 In any case the length of the flue shall not be less than 4.6m from the ash floor protector.
 In some situations the Local Council may vary the above requirements.
2. The flue system must be tested and comply with AS/NZS2918:2001, Appendix F.
3. The insulation boundary shield shall be capable of preventing accidental migration of loose-fill or any combustible material by any action of wind or by persons moving in the ceiling space.

Note: All measurements are in millimetres. The rear clearance from the top rear lip of the fire is 100mm, i.e. 120mm from the (recessed) rear panel.

These instructions, spare parts information, operation and maintenance guides may be downloaded from our website www.yunca.co.nz

FIG C: HEATER DIMENSIONS – Fitzroy (Drawings on this page not drawn to scale)

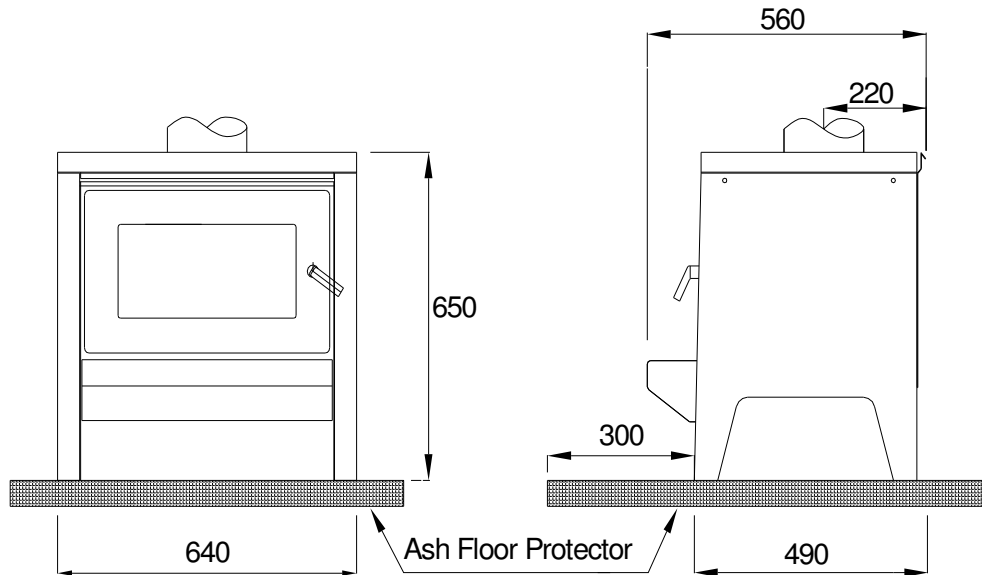
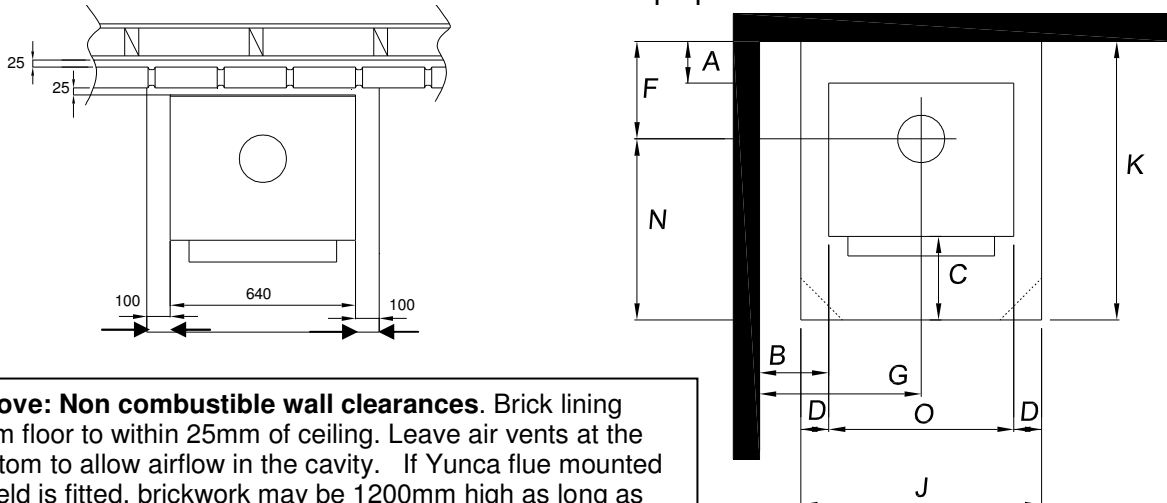

FIG D: HEATER POSITION.

* **N.B.** Measurement “A” is taken from the top lip at the rear of the fire.



Above: Non combustible wall clearances. Brick lining from floor to within 25mm of ceiling. Leave air vents at the bottom to allow airflow in the cavity. If Yunca flue mounted shield is fitted, brickwork may be 1200mm high as long as all vertical joints in top and bottom of brickwork are left out to allow airflow when brickwork is capped.

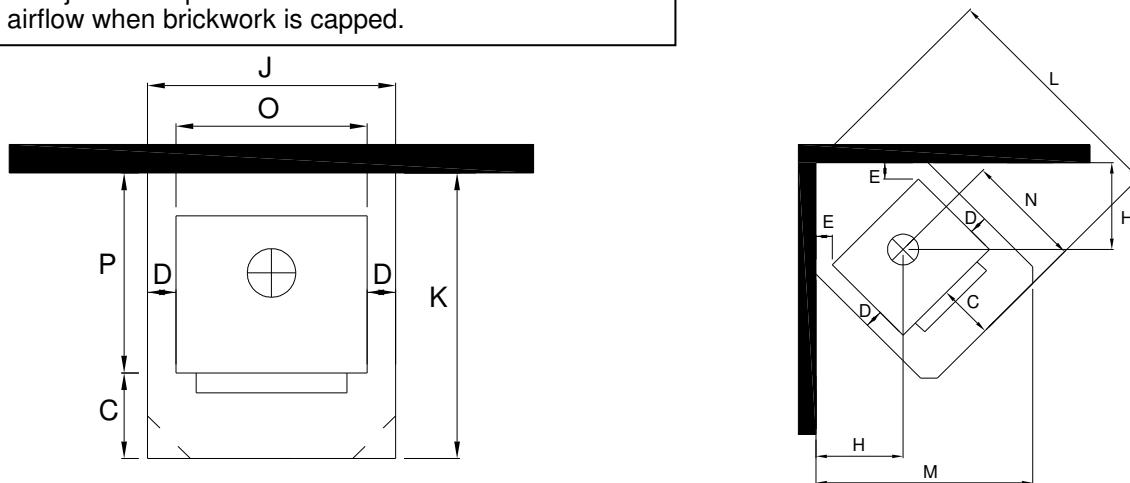

FIG D: MINIMUM FIRE TO COMBUSTABLE WALL CLEARANCES – FITZROY SUB 1.0 (WITH YUNCA FLUE MOUNTED SHIELD FITTED). Measurements in millimetres.

A *	B	E	F	G	H
100	300	130	320	620	501

FIG D: MINIMUM FLOOR PROTECTION MEASUREMENTS (WITH YUNCA FLUE MOUNTED SHIELD FITTED). Measurements in millimetres.

C	D	J	K	L	M	N	O	P
300	100	840	880	1274	1150	560	640	580

FLUE SYSTEM REQUIREMENTS FIG. E

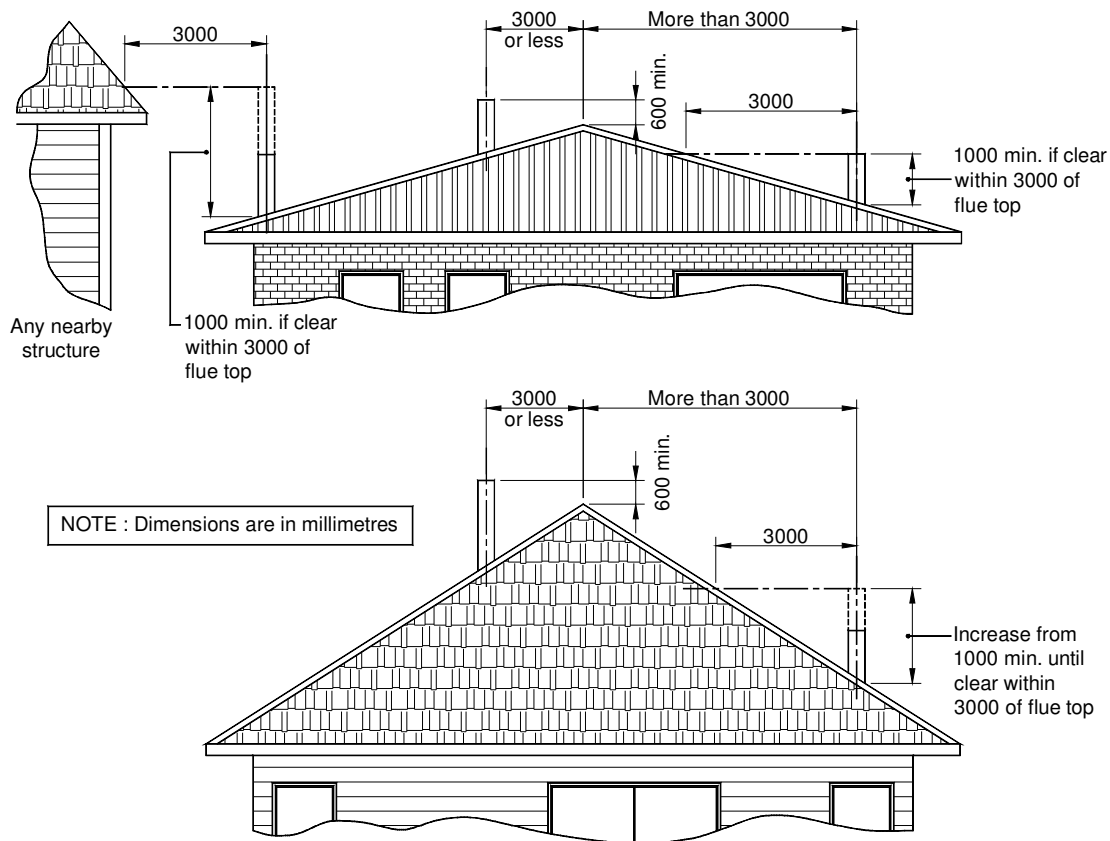

MINIMUM HEIGHT OF FLUE SYSTEM EXIT

IMPORTANT INFORMATION

- A. THE APPLIANCE AND FLUE SYSTEM SHALL BE INSTALLED IN COMPLIANCE WITH AS/NZS 2918:2001 AND THE APPROPRIATE REQUIREMENTS OF THE RELEVANT BUILDING CODE OR CODES.
- B. APPLIANCES INSTALLED IN ACCORDANCE WITH THIS STANDARD SHALL COMPLY WITH THE REQUIREMENTS OF AS/NZS 4013 WHERE REQUIRED BY THE REGULATORY AUTHORITY I.E. THE APPLIANCE SHALL BE IDENTIFIABLE BY A COMPLIANCE PLATE WITH THE MARKING "TESTED TO AS/NZS 4013"
- C. ANY MODIFICATION OF THE APPLIANCE THAT HAS NOT BEEN APPROVED IN WRITING BY THE TESTING AUTHORITY IS CONSIDERED TO BE IN BREACH OF THE APPROVAL GRANTED FOR COMPLIANCE WITH AS/NZS 4013
- D. MIXING OF APPLIANCE OR FLUE SYSTEM COMPONENTS FROM DIFFERENT SOURCES OR MODIFYING THE DIMENSIONAL SPECIFICATION OF COMPONENTS MAY RESULT IN HAZARDOUS CONDITIONS. WHERE SUCH ACTION IS CONSIDERED, THE MANUFACTURER SHOULD BE CONSULTED IN THE FIRST INSTANCE.
- E. CRACKED AND BROKEN COMPONENTS E.G. GLASS PANELS OR FIRE BRICKS, MAY RENDER THE INSTALLATION UNSAFE.

IF A WATERBOOSTER IS FITTED:

NOTE: A WATER BOOSTER CANNOT BE FITTED TO THE FITZROY (SUB 1.0) CLEAN AIR MODEL

- A. DO NOT CONNECT TO AN UNVENTED HOT WATER SYSTEM
- B. INSTALL IN ACCORDANCE WITH AS 3500.4.1 OR NZS 4603 AND THE APPROPRIATE REQUIREMENTS OF THE RELEVANT BUILDING CODES.

SEISMIC RESTRAINT

Secure the heater base to the hearth or sub-framing with dynabolts or similar through the holes provided. Follow local Council's Specifications.