



# LEEDZ

## FUZZY LOGIC control



# FREESTANDING GAS HEATER

**FEBRUARY 2010**

# INSTALLATION, OPERATION, MAINTENANCE & WARRANTY INFORMATION

These instructions should be stored in a convenient safe place for ready reference.

<b>CONTENTS:</b>	<b>PAGE</b>
<b>INTRODUCTION</b>	3
<b>INSTALLATION</b>	4 – 7
FLUE INSTALLATION	5
CLEARANCES	6
CONNECTION TO GAS SUPPLY	7
GAS PRESSURE REQUIREMENTS	7
<b>OPERATIONS</b>	
REMOTE CONTROL, AUTO TIMER	8 - 10
MANUAL CONTROL OPERATION	11
<b>MAINTENANCE</b>	
DOOR REMOVAL, GLASS REPLACEMENT	11
GLASS CLEANING, DOOR ROPE REPLACEMENT	12
BATTERY BACK UP	12
SERVICE INSPECTION AND CLEANING	13
GAS CONTROL VALVE CONNECTIONS	13
FAN REMOVAL	14
TROUBLE SHOOTING GUIDE	15 - 16
Appendix A PARTS LIST	17
Appendix B INJECTOR SIZES	17
Appendix C WARRANTY	18
Appendix D WIRING DIAGRAM	18
Appendix E WARRANTY REGISTRATION	19

## INTRODUCTION

**Welcome, and congratulations on purchasing your YUNCA LEEDZ (Fuzzy Logic control) FLUED GAS HEATER.**

Please read the following carefully before attempting to operate the heater and ensure all members of your home understand how this elegant and highly efficient heater functions.

Please fill out and return the registration card promptly (back page).

These instructions should be stored in a convenient safe place for ready reference. If you have any questions regarding your heater please contact your YUNCA dealer.

The YUNCA **LEEDZ** (Fuzzy Logic control) FLUED GAS HEATER is a gas-fired, conventionally vented, room heater tested by independent laboratories to Australian and New Zealand standards.

Electronic ignition and operation is by an infra-red remote control handpiece (Ref page 8-10). However if your remote is mislaid or damaged there is a convenient manual control panel (page 11) on the front of the fire. Both the remote and the control panel feature “kiddy-lock” controls for added peace of mind. We highly recommend the use of the two-speed fan boost on the fire for greater heating efficiency.

Should power not be available for any reason, battery back up through two “D” sized batteries ensures the fire will continue to operate (without the fan boost). Ref page 12.

The installation of the YUNCA **LEEDZ** (Fuzzy Logic control) FLUED GAS HEATER must be carried out by a suitably qualified person and comply with the current New Zealand installation code, NZS 5261:2003.

**CAUTION: THIS APPLIANCE MUST BE FLUED TO ATMOSPHERE.**

Installation and repair of the YUNCA **LEEDZ** (Fuzzy Logic control) VENTED GAS HEATER must be done by a qualified person.

**The appliance should be serviced at least annually by a qualified service person.** Control valve compartments, burners, fan, and air circulating passageways of the LEEDZ (Fuzzy Logic control) must be kept free from any lint and dust build-up to ensure efficient and safe operation of the heater.

**CAUTION: DO NOT PLACE ARTICLES ON OR AGAINST THIS APPLIANCE.** This particularly applies to the remote control handpiece!

**CAUTION: DO NOT USE OR STORE FLAMMABLE MATERIALS NEAR THIS APPLIANCE.**

**CAUTION: DO NOT SPRAY AEROSOLS IN THE VICINITY OF THIS APPLIANCE WHILE IT IS OPERATIONAL.**

# INSTALLATION

The most desirable and beneficial location for a **YUNCA LEEDZ** (Fuzzy Logic control) heater is in the centre of a building, thereby allowing the most efficient use of the heat created.

The location of windows, doors and the traffic flow in the room where the heater is to be located, should all be considered, as should the availability of power supply to the fan boost.

If possible a location should be selected that allows the flue pipe to be installed simply and pass through the house without cutting a floor or roof joist. Refer to page 5 for typical flue installation (Fig 2).

To obtain maximum heat distribution with any freestanding heater a ceiling fan may be fitted.

When the appropriate position has been selected the unit must be bolted to the floor to ensure that the unit remains upright in the event of an earthquake or similar (Fig 1 below). If the heater is being attached to a concrete floor dyna bolts should be used, if the floor is wooden the bolts used should be long enough to go fully through the floorboards and fixed with nuts and washers from the underside. The earthquake brackets are located at the back corners of the heater.

The **Yunca Leedz** does not require a floor protector (hearth), and if desired can be placed directly on to carpet or wood flooring.

**CAUTION:** The gas fire must be permanently attached as shown.

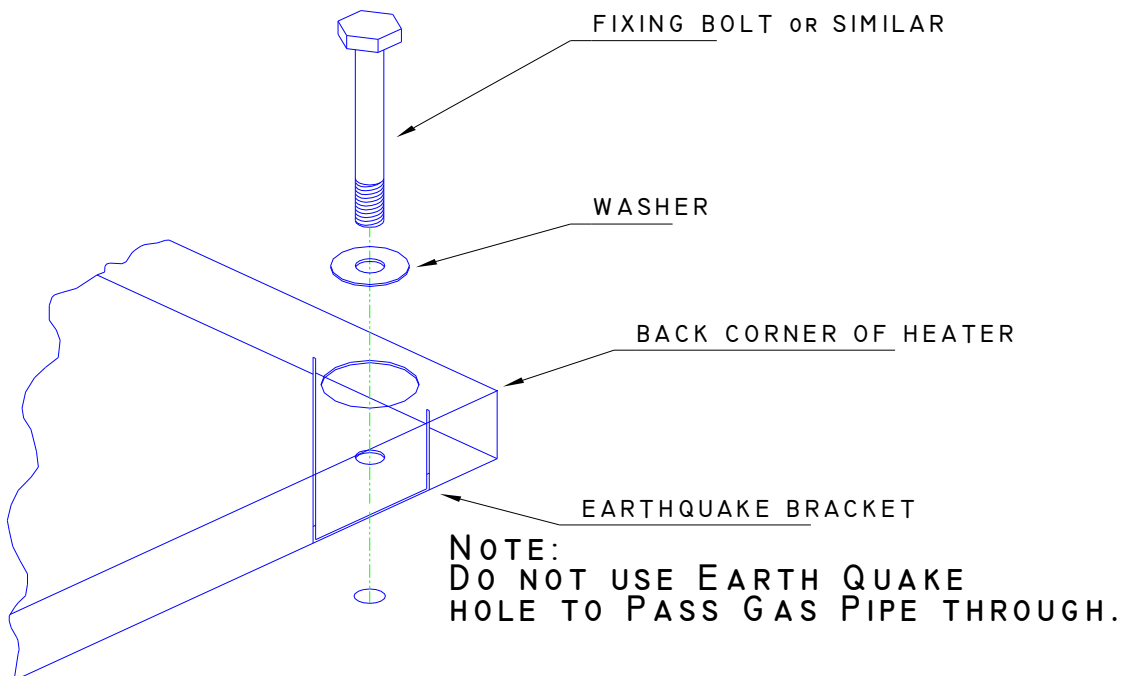

# TYPICAL FLUE INSTALLATION

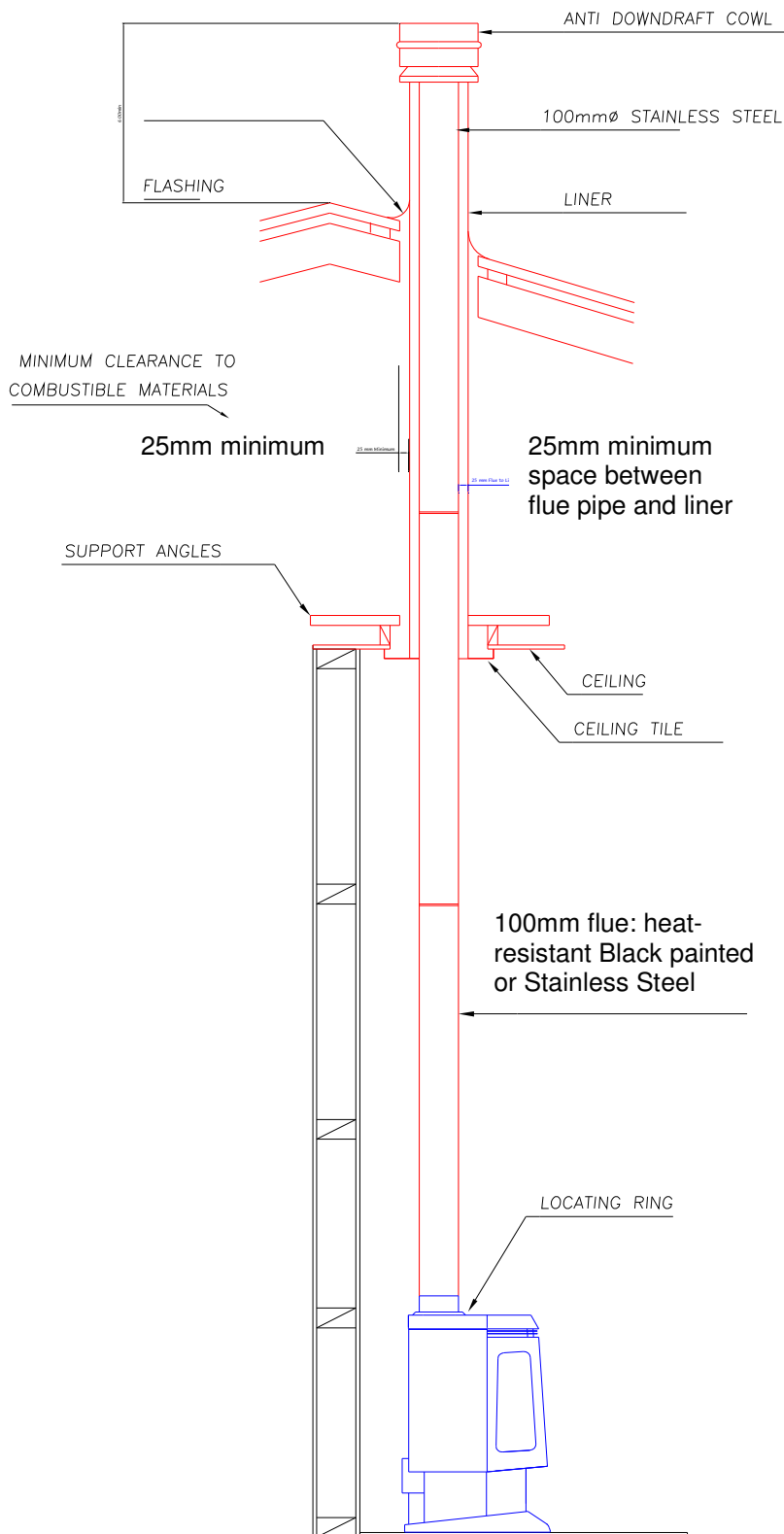

## CONDITIONS FOR FLUES

1. The flue shall extend to :
  - (a) in the case of a pitched roof not less than 600mm above the highest point of the roof.
  - (b) In the case of a flat roof (i.e. any roof with a pitch of less than 30°), not less than 1500mm above the highest point of the roof.

In any case the length of the flue shall not be less than 3 metres from the top of the appliance flue spigot.

2. When loose fill insulation is used in the adjacent ceiling space, maintain clearance between the liner and the insulation by provision of a boundary extending 200mm above the ceiling top surface. The boundary may be of any material capable of preventing accidental migration of the loose fill by any action of wind or by persons moving about in the ceiling space.

NOTE: Seal Flue Joints.

(Fig 2)

# CLEARANCES and DIMENSIONS

The YUNCA **LEEDZ** (Fuzzy Logic control) FLUED GAS HEATER should be installed with clearances equal to or greater than those recommended below (Fig 3) and comply with NZS 5261/ AG601.

This is to ensure adequate air circulation around the heater and avoid heat damage to wall coverings.

Note: If walled surface is non-combustible (i.e. brick or steel), side clearances may be reduced to 100mm, **however note** that this may severely restrict access to the appliance for servicing. Corner positions and back clearance remains the same. (See Fig. 3 Below)

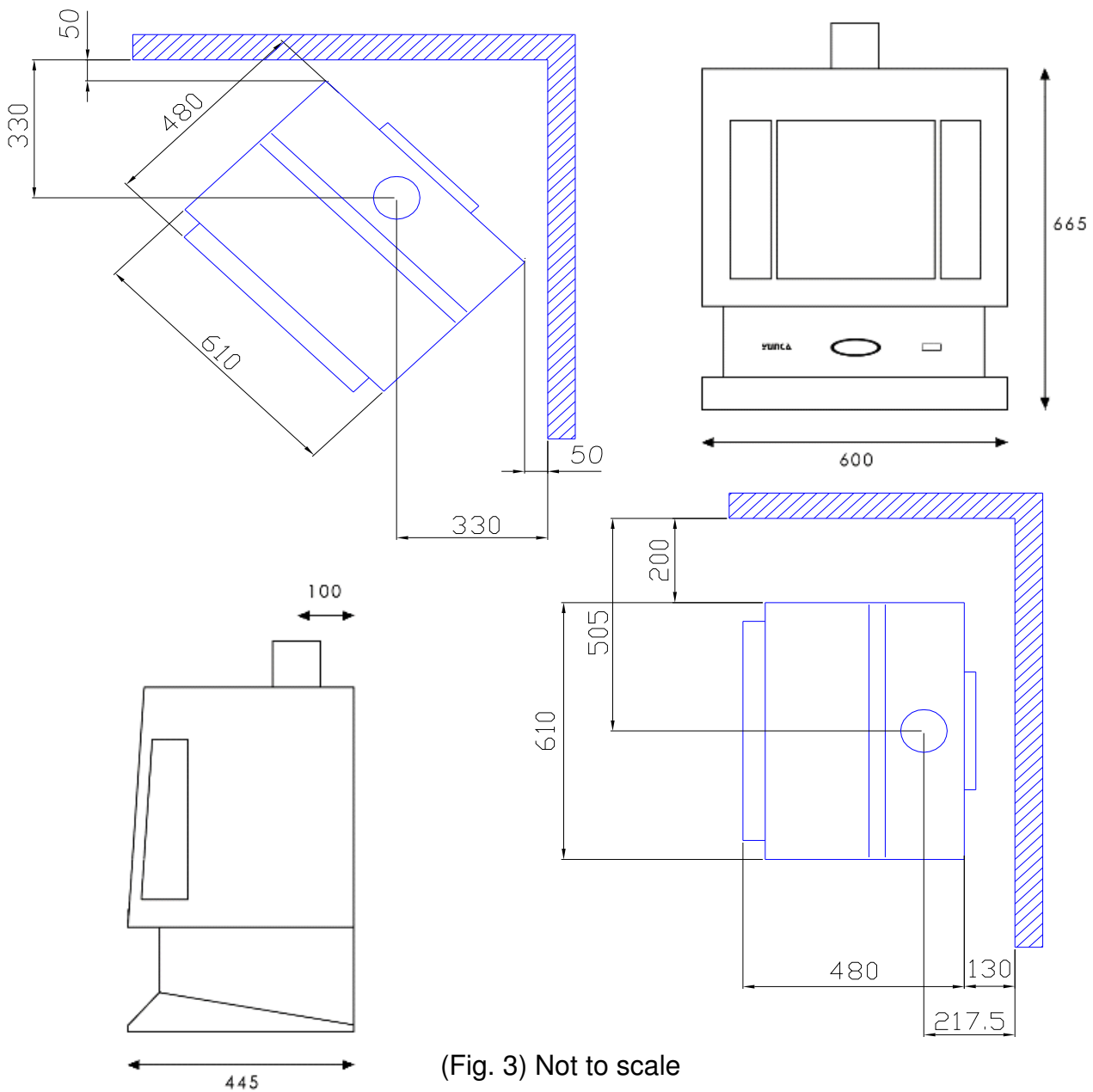

(Fig. 3) Not to scale

# CONNECTING THE HEATER TO A GAS SUPPLY

**Burn only the fuel for which the heater is equipped.**

The YUNCA **LEEDZ** (Fuzzy Logic control) is shipped from the factory equipped to burn either Natural Gas or L.P.G. **N.B. The Yunca LEEDZ (Fuzzy Logic control) Heater cannot be converted from LPG to NG, or vice versa.** The data plate affixed to the back of the heater specifies the gas type, which the heater is factory equipped for.

## Gas connection:

The gas inlet is located at the back left hand corner of the heater. The inlet thread is to a male 3/8" BSP

**A separate gas isolation valve should be installed immediately up stream of the connection to the appliance.**

**WARNING:** To stop pipe compounds entering the gas line, do not apply sealing compounds to the first two threads at the tip of any gas connection.

Ensure all gas pipes to the heater are purged by blasted air to remove any material or filings that may block valves and jets.

All joints should be tested for leaks before operating the heater.

## TO CHECK GAS PRESSURE:

- 1 Remove the front plinth cover (two screws at top of cover).
- 2 Test point can be seen on the left side of the control box.
- 3 Slacken test point screw and check pressures.
- 4 Re-tighten test point screw.

## GAS PRESSURE REQUIREMENTS:

Correct gas pressure and the use of a properly sized gas supply line is essential for the safe and efficient performance of this appliance. The inlet pressures at the control must be tested on installation following the procedure below.

**Note: Improper gas pressure will affect heater performance flame colour or cause pilot malfunction.**

### Natural Gas:

Input	33MJ
Static Minimum inlet operating pressure	2.0 kPa (8"w.g.)
Minimum inlet operating pressure	1.0 kPa (4"w.g.)
Maximum inlet pressure	5.0 kPa (20"w.g.)

### L.P.G.:

Input	28MJ
Static Minimum inlet operating pressure	2.75 kPa (11"w.g.)
Minimum Inlet operating pressure	2.50 kPa (10"w.g.)
Maximum inlet pressure	3.50 kPa (14"w.g.)

**CAUTION:** Do not use this heater if any part has been water damaged or exposed to moisture causing corrosion. A Qualified service technician should inspect the heater and replace any part of the gas system that has been water damaged.

# LEEDZ INFRA-RED REMOTE CONTROL with AUTO TIMER.

N.B.- DO NOT LEAVE THE REMOTE CONTROL ON TOP OF YOUR FIRE!

## REMOTE CONTROL DISPLAY



### POWER ON

Power ON Welcome Display.



### POWER OFF

Power OFF Display.



### IR OPERATION

Infra-Red Injection Display.



### AUTO SET

AUTO functions in use.



### BATTERY

Battery Power too low.



### PROG1

The 1st AUTO START and AUTO STOP display.



### FLAME HEIGHT

High flame, medium flame and low flame levels display.



### PROG2

The 2nd AUTO START and AUTO STOP display.



### PILOT

Pilot ON display.



### AUTO START

PROG1 and PROG2 AUTO START setting.



### FUZZY

FUZZY flame mode 6 sections. Each press one section.



### AUTO STOP

PROG1 and PROG2 AUTO STOP setting.



### FLAME MODE

Flame mode display.



### AUTO SET ERROR

PROG1 and PROG2 AUTO SET invalid or error settings.



### CLOCK

CLOCK function in use.



### WEEKDAY

Weekdays display.

## LEEDZ INFRA-RED REMOTE CONTROL with AUTO TIMER.

**POWER ON/OFF:** First check that two fresh AAA batteries are inserted. If the remote appears faulty, please try replacing the batteries. At first the remote may appear to be on, but it is likely that is not so.

To turn on the remote control (it is protected with a “kiddy lock”), press and hold the **POWER** button for about 2 seconds until “off” disappears from the screen, then release to unlock the safety feature. One short press of the **POWER** button will turn on power to the remote control, and also start the fire on the **MANUAL - HIGH** setting. Current mode / settings will be displayed. The fire will always start in manual operating mode on a high setting. (Also refer to the next page for further information). There is an audible beep when the fire receives a signal from the remote, range is approximately 5 metres.

**CLOCK SETTING:** Press the **CLOCK** button once (“clock” in the display will start flashing). Press **WEEK** to set the week day, press **HOURL** to set the hour, taking care to check if on a.m. or p.m. Press **MIN** to set the minute (holding the button down will advance the minutes quicker). Press **CLOCK** to save the setting.

**MANUAL “FLAME” OPERATING MODE** has three settings: High, Medium and Low. Heat output is fixed to the setting and needs to be adjusted manually by pressing the **TEMP** “ – “ and “ + “ buttons.

**“FUZZY LOGIC” OPERATING MODE** replaces the traditional thermostat operation with six “comfort levels”. Press **MODE** to switch between **Manual** and **Fuzzy Logic**, and use the **TEMP** “ – “ and “ + “ buttons. Choose the comfort level that best suits your needs. Every now and then the fire will give a short boost of heat and then return to your chosen setting. This is the most economical way to operate your Yunca Fuzzy Logic control fire.

**HINT:** The two speed fan is designed to quickly transfer heat around the room and ensures the most economic gas use. The three-position switch (HIGH / OFF / LOW) is located on the right side plinth.

**AUTO FUNCTION:** To set this feature you will need to ensure the remote control is on (as advised above), and ensure the **CLOCK** time and day are correctly set. PLEASE NOTE: If a key is not pressed for 7 seconds, the programming will “time out” and you will need to re-start the process.

Set times to Start and/or Stop the fire with a choice of up to two daily programme settings (**PROG1** and **PROG2**). You can choose to use only **PROG1** if only one setting is needed. Heat output on Auto is initially run in manual control, and once the fire is operating you can then switch to the more economical Fuzzy Logic.

**EXAMPLE:** Set **PROG1** to start at 6:00 am, stop at 8.00am. Set **PROG2** to start at 4.30pm, stop at 10.30pm Monday to Friday. Both **PROG1** and **PROG2** may have different settings programmed for the weekend if required.

**TO SET:** Press **PROG1** to set the “timer on” setting (Mon-Fri). Now choose the desired heat output (High, Med or Low) Press **HOURL** button, making sure you have chosen the correct a.m. or p.m. time, then press **MIN** button (increases in 10 minute steps) to set the start time. Press **PROG1** again and use the **HOURL** / **MIN** buttons to set the stop time. Press **CANCEL** at any time to clear the setting currently on screen (i.e.either Start or Stop). If you are not setting weekend programming, just press **PROG1** to save your settings and exit the programming function.

If you wish **PROG1** to operate on Saturday and Sunday, press **WEEK** button to set start time, using **HOURL** and **MIN** buttons as described above. Then press **PROG1** again to set the weekend stop time, and press **PROG1** once more to save your settings and exit the setting mode.

Continue as above using **PROG2** if required. To check the programme settings press either Prog1 or Prog2.

...Important Info Continued on page 10...

**AUTO FUNCTION CONTINUED:** Once the times are set, press the grey **AUTO SET** button and leave the remote near, but not on, the fire or the fire will not operate automatically. When the **AUTO SET** button is pressed you will hear a long beep. When the fire is turned off the green light on the front control panel (Page 11, Fig 4) will flash slowly to show AUTO is set, and you will see the AUTO symbol display on the LCD screen of the remote control unit.

**IMPORTANT:** Press **AUTO SET** button again to cancel the auto feature or the fire will continue to operate to the automatic settings, even if the remote is "off".

**NOTE** – Even when **AUTO SET** is activated (i.e. the display shows **AUTO** on the remote and the green light on the fire is flashing) you can continue to operate the fire (i.e. turn it on and off, change mode and heat output) without affecting the automatic feature settings. You are effectively temporarily overriding the automatic control, e.g. if you wish to stop the fire running at an earlier time.

## BK368 ALL-IN-ONE WITH REMOTE CONTROL

### REMOTE CONTROL OPERATIONS



#### POWER ON/OFF

Press POWER for 2 seconds to unlock the safety Lock-out then release the button. Press POWER to turn the system On/Off.



#### TEMP +

Increase flame level from low to medium. Increase flame level from medium to high.



#### TEMP -

Decrease flame level from high to medium. Decrease flame level from medium to low.



#### FUZZY Mode

Press Mode for FUZZY six flame sections settings. Press TEMP+ to increase flame level and TEMP- to decrease flame levels.



#### CLOCK

Enter for time setting and confirm the setting. No press in 10 secs will return to ex-time. One more press CLOCK can change the setting. Start CLOCK function will clear AUTO setting. Reset time everytime when change battery.



#### WEEK Set

Press WEEK button for Weekday setting. Every press will increase one day.



#### HOUR Set

Press HOUR button for hours setting. Every press will increase one hour.



#### MINUTE Set

Press MIN button for minutes setting. Every press will increase one minute. Keep pressing MIN button for quick set.



#### AUTO SET

Press AUTO SET button Buzzer will give a long Beep (2 secs), Green Light on the front board of Control Unit will flash (ON - 2 secs and OFF 0.5 secs). Re-press AUTO SET will cancel the settings. Buzzer will give one short Beep, Green Light will stop flashing.



#### PROG1

Reserve the system AUTO START and AUTO STOP. Press this button ex-AUTO settings will be cleared. Press PROG1 button LCD will start blinking.

Use WEEK, HOUR, MIN, TEMP+, TEMP- to set the desired AUTO START time.

WEEK : From Mon to Fri; From Sat to Sunday. two kinds of modes.

HOUR : Every press increase one hour.

MIN : Every press increase 10 minutes.

TEMP+ : Choose High, Medium or Low Flame Level.

TEMP- : Choose High, Medium or Low Flame Level.



#### CANCEL

Press CANCEL to clear PROG1 settings. One more press CANCEL button will quit PROG1, no reservations are memorized.

Use WEEK, HOUR, MIN, TEMP+, TEMP- to set the desired AUTO STOP time.

WEEK : From Mon to Fri; From Sat to Sunday. two kinds of modes.

HOUR : Every press increase one hour.

MIN : Every press increase 10 minutes.

TEMP+ : Choose High, Medium or Low Flame Level.

TEMP- : Choose High, Medium or Low Flame Level.



#### PROG2

Reserve the system AUTO START and AUTO STOP. All of setting procedures are same as PROG1.

**Once AUTO SET functions, the memory will not be cleared unless the users cancel the function.**

## MANUAL CONTROL PANEL OPERATION

Should the remote control be mislaid or damaged, your fire can be operated using the **control panel on the front of the fire**, (Fig 4) located on the front panel.

Press and hold the **POWER** button to light the fire (starts on high).

Press again to reduce to medium, and again to reduce to low.

A further press of the power button will turn the fire off.

The **PWR** light will flash if battery is low.

The **AUTO** light will flash (when the fire is off) as a reminder that the timer has been activated.

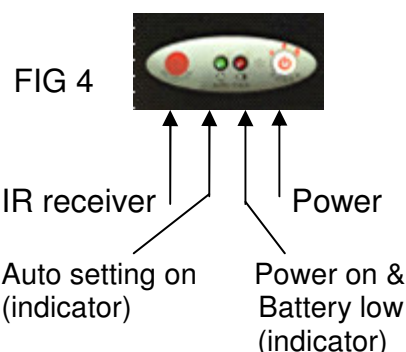

## MAINTENANCE

A qualified service person should conduct an annual inspection and undertake any maintenance required on your **LEEDZ** (Fuzzy Logic control). Its' venting and installation must be checked to keep it running safely and efficiently.

## REMOVING THE FRONT DOOR

**Note:** The door can only be removed after the heater has been turned off for long enough so that the door has cooled to touching temperature.

1. First the side panels must be removed, to do this grip panel at its base and pull out. The panel should be swung out to about 30 degrees and then pulled down to release the locating pins in its top.
2. This will expose the restraining latches at each side. To open these latches lift the butterfly grip forward and twist it through 180 degrees. Ensure that the latch hook is clear of the door frame.
3. The front door can now be removed by gripping it by its back bottom corners and pulling it straight back and out towards you.  
Note: It is important not to spread the sides out any further than is necessary to remove door, as this may damage the enamel coating on the door.

## REMOVING THE GLASS FOR REPLACEMENT

1. Remove the front door as described above, and place front down on a soft surface.
2. Remove the two side glass retainers by taking out the three bolts in each one.
3. Remove the bottom front glass retainer by taking out the four screws along the base of the door.
4. To remove the front glass place one hand under it and lift it up and out of the doorframe.
5. Remove the side glasses
6. New glass (1610LFF, 1610LFS) and thermotape seal (1611LFF, 1611LFS) can be ordered through your YUNCA agent.  
Note: Only recommended heat resistant glass may be fitted.
7. Place replacement glass in position in the reverse order of removal, i.e. Side glass should be placed in position before front glass.
8. Replace side and bottom glass retainers with their respective bolts and screws.  
Note: Tighten the screws and bolts alternately, do not over tighten to avoid damaging glass.

## MAINTENANCE (cont)

### CLEANING THE GLASS

The glass may be cleaned with damp paper towels. Ceramic glass cook top cleaner may also be used. The inside of the glass may also need cleaning from time to time (refer page 11 for glass door removal information).

**Note: Never clean the glass when it is hot. Do not use abrasive cleaners on the glass.**

### CLEANING THE CHASSIS

The enamelled chassis may need cleaning from time to time to remove a white film (refer page 11 for glass door removal information). The chassis is enamelled so a wipe over with a damp cloth, when the chassis is cool, will be sufficient.

### REPLACING THE DOOR ROPE (GASKET)

The YUNCA **LEEDZ** (Fuzzy Logic control) has a 10mm fibreglass gasket (1608LF) surrounding the front and side glass. Should it ever need replacement, use only the replacement gasket that is available from your YUNCA dealer.

#### **Procedure:**

1. Remove the front door as described on previous page.
2. Remove the existing gasket and clean the channel of all loose material.
3. Lay a thin bed of gasket cement (PVA glue) around the length of the channel
4. Lay the gasket in the channel ensuring the gasket is not stretched.
5. Replace the door carefully to avoid dislodging the gasket.

### BATTERY BACK UP REPLACEMENT

Your **YUNCA GAS LEEDZ** (Fuzzy Logic control) will operate (WITHOUT FAN BOOST) if power is not available for any reason.

Two "D" size batteries are located on the right side plinth panel. Unclip the cover from the top, (it is hinged at the base), and remove the batteries, replacing with fresh ones. The cover shows the polarity of the batteries.

Take care when working near an operating heater, it will be hot!

Batteries will operate the back up system for about 200 hours. Fan boost cannot run on battery back up.

**Always ensure the batteries are fresh**, and consider changing these once a year (end of summer daylight saving time, when you change your smoke alarm batteries, is a good routine. You will have fresh batteries for the coming winter). Batteries left too long may leak and damage the contacts, so take note of the recommendation to change them annually.

## MAINTENANCE (cont).

The following procedures should be performed only by a qualified service person. The gas supply and electrical power should be isolated whenever any maintenance procedures are undertaken.

### CLEANING THE LOG SET AND FIREBOX

During the annual inspection and maintenance appointment, **the service person** should clean dust, lint and any light soot accumulation from the logs and the fire box area. An extra soft brush should be used on the logs, as they are extremely fragile. If at any time the logs cannot be removed or installed without force, the cause must be found. The logs must never be forced.

#### Procedure:

1. Remove Front Door as described on page 11.
2. Remove the complete log set from the firebox by lifting it up and out. Brush it gently over a newspaper and carefully place it out of the way.
3. The bark tray can be removed by lifting its feet over the bottom gasket retainer and pulling it straight out, with the bark still on it.
4. The bark consists of a mixture of vermiculite and composite chips and it can be dusted by sieving. If needed a replacement bag can be ordered through your YUNCA dealer. (See parts list for reference number)
5. With firebox empty, a vacuum cleaner can be used to remove any visible dust and lint from within the firebox area.
6. Replace the bark tray.
7. Replace log set and redistribute bark.
8. Replace and relatch the front door and close the side panels.

### INSPECTING THE VENTING

An inspection of the venting system should be made during the annual service appointment. There must be no blockages and the flue must be in good repair. Any sections that are taken apart for inspection must be reassembled and sealed as required.

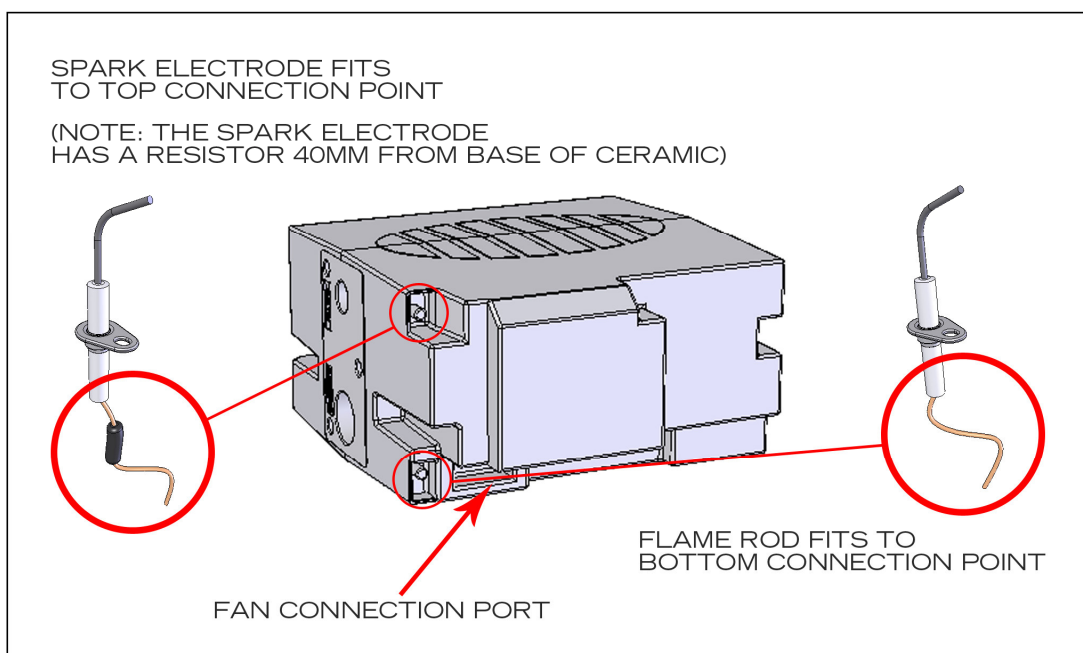

FIG 5: **GAS CONTROL VALVE CONNECTIONS**

## MAINTENANCE (cont).

### HOW TO REMOVE FAN

**NOTE: Disconnect Main Power first**

1. Remove front cover.
2. Disconnect the wiring from switch.
3. The earth wire must be unplugged and the plastic conduit adaptor removed from its retaining bracket.
4. Disconnect earth wire from control valve bracket.
5. Unplug white connector block.
6. Slacken the four screws that attach the fan mounting bracket to the base.
7. Remove fan.

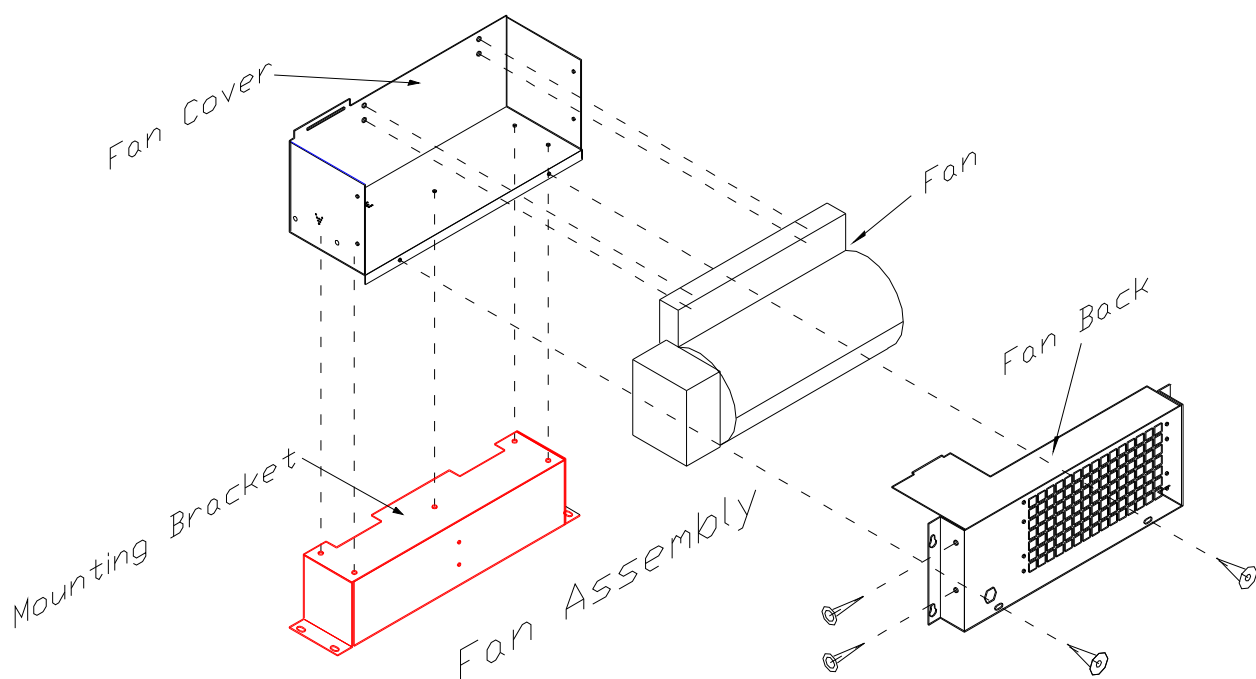

## TROUBLESHOOTING GUIDE –YUNCA FUZZY LOGIC CONTROL SYSTEM P1/2

<u>PROBLEM</u>	<u>POSSIBLE CAUSE</u>	<u>SOLUTION</u>
A. After turning on the appliance it will not operate, the PWR (power) indicator on the control panel (Fig 4) is not lit up.	▪ AC Power IS unplugged or loose, or the fuse has a short	Reset the Power Plug or replace the Fuse. (fuse box is located below “AC in”, and slides out, spare fuse within)
	▪ Battery power is too low when using DC power ▪ Battery Box has a failure or the connector pins are loose.	Change battery or adjust the connector pins Replace the Battery Box.
	▪ IR Receiver (Fig 4) is covered.	Uncover the IR Receiver.
	▪ POWER button of Remote Control Unit was not pressed for long enough.	Press POWER button for 2 seconds and release, then press POWER button again.
	▪ Remote Control Unit has failed or there is no battery power.	Replace with new batteries or manually press the PWR button on the front plate (Fig 4, page 11). Check remote control batteries.
	▪ The connection wires between Front Control Board and Rear Control Board are loose or have failed.	Re-arrange the connection wires or replace with a new wire set. When replacing the wire set, use (-) type screwdriver to first remove the plastic cover.
	▪ Front and Rear Control Board have a failure.	Replace Rear Control Board first. If still not working replace Front Control Board.
B. After turning on the appliance, it will not spark.	▪ Gap between Spark Igniter and Grounding or sparking gap is too big	Adjust the gap to $4 \pm 0.5$ mm. (Cable Resistor should be connected close to spark Igniter.)
	▪ Ceramic of Spark Igniter breaks or fails	Replace with a new one.
	▪ High Voltage Cable has loosened, broken or has a short.	Reset or replace with a new one.
	▪ Pilot Set is not grounded.	Pilot tube must be grounded (Fix on the Control Valve)
	▪ Rear Control Board has a failure.	Replace with a new one.
C. Sparking exists but pilot flame will not light up.	▪ No gas supply.	Check Test Point (by manometer) for gas pressure (Pg 7).
	▪ Poor wire connection between Front and Rear Control Board or connection wires have loosened.	Re-arrange or replace a new wire set.
	▪ Pilot Injector is blocked.	If there is gas pressure, it's necessary to replace Pilot Set or clean the injector. Nozzle diameter: LPG: 0.35 mm, NG: 0.55 mm.
	▪ Rear Control Board has a failure.	Replace.

## TROUBLESHOOTING GUIDE–YUNCA FUZZY LOGIC CONTROL SYSTEM continued P2/2

<u>PROBLEM</u>	<u>POSSIBLE CAUSE</u>	<u>SOLUTION</u>
D. Pilot is alight, sparking continues and doesn't stop. (No flame is sensed.)	The cables of Flame Sensor and Spark Igniter are reversed or loosened.	Re-arrange or tighten.
	Flame Sensor doesn't sense the flame.	Re-adjust to a suitable position to be burnt by the flame.
	Pilot Flame is burnt inside the pilot tube.	Tighten Pilot nut Replace Pilot Set.
	Rear Control Board has a failure.	Replace.
E. Pilot is alight, main burner cannot light up.	The wire set has a failure or the terminals have loosened.	Re-arrange or replace.
	Nozzle of Main burner is blocked.	If there is gas pressure, it's necessary to replace Pilot Set or re-drill the injector.
	Front and Rear Control Board have a failure. Remote Control Unit has a failure.	Replace.
F. Low Flame is alight; Medium Flame doesn't light up.	The wire set has a failure or the terminals have loosened.	Re-arrange or replace.
	Valve "M" has a failure or Nozzle of Valve "M" is blocked.	Refer to factory
	Front Control Board has a failure. Remote Control Unit has a failure.	Replace.
G. Medium Flame is alight; Low Flame doesn't light up.	The wire set has a failure or the terminals have loosened.	Re-arrange or replace.
	Valve "L" has a failure or Nozzle of Valve "L" is blocked.	Refer to factory
	Front Control Board has failed. Remote Control Unit has failed.	Replace.
H. During Spark Ignition cycles, the appliance doesn't shut down in 25 seconds.	Front Control Board has a failure	Replace.
I. AUTO function fails. (Cannot AUTO turn on and AUTO turn off the appliance.)	Timer control incorrectly set (e.g. am or pm settings) AUTO function not turned on (Pg 9)	Check timer controls settings
	Front Control Board has a failure. Remote Control Unit has a failure.	Replace.
J. No FUZZY functions	Front Control Board has a failure. Remote Control Unit has a failure.	Replace.
PWR indicator on the front plate flashes. Remote Control Unit displays weak battery.	Battery power is low.	Replace the batteries in Battery Box. (2 x D size)  Replace batteries in the Remote Control Unit. (2 x AAA)

## APPENDIX A

### PARTS LIST – LEEDZ FS (FuzzyLogic):

PART NO.	PART NAME
6601	Rear Burner - SIT
6699L	Front Burner – Furi 316
6602A	Pilot assembly
6598RF	Flame rod lead (LFS / Fuzion)
6598SF	Electrode lead (LFS / FUZION)
6680*	Cross ignition channel (LPG/NAT)
6600A	Control Valve BK368
6701R	Remote control hand piece (Fuzzy Logic)
6702	Battery Box
1955	3 position rocker switch
6699	Fan only (unwired) QLZ06/1200 A49
6624G	Fan assembly - complete
6611G	Otago Bay Log Set assembly
6611C	Logset twig
88**LFzR	Right side panel (State Colour)
88**LFzL	Left side panel (State Colour)
83**LF2	Top panel (State Colour)
89**LF2	Main door (State Colour)
8106LF	Front Grill
1608LF	Leedz FS Door rope
1610LFF	Leedz FS Front door glass
1610LFS	Leedz FS Side door glass
1611LFF	Leedz FS Front glass packing
1611LFS	Leedz FS Side glass packing

## APPENDIX B

### INJECTOR SIZE:

GAS TYPE	FRONT BURNER	BACK BURNER
NATURAL	2.3mm diameter	2.3mm diameter
L.P.G.	1.15mm diameter	1.15mm diameter

# APPENDIX C

## WARRANTY

Components of the Yunca Leedz Free Standing Gas Heater are warranted for a period of one year from date of purchase. This includes all gas and electrical components including control, burners, pilot assembly, tubing, fan and switches.

Glass and surface coatings are also warranted for one year.

The heater panels and firebox are covered by a limited Five-Year Warranty against defects in materials and workmanship.

Damage caused by neglect, improper use, acts of god, theft, or any other indirect, incidental cause are not covered by this warranty.

**This warranty is void if the recommended service schedule is not implemented and carried out by a suitably qualified person as suggested in this manual.**

### Limitations of Liabilities:

Yunca Heating hereby waives any liability for incidental and consequential damage directly or indirectly sustained, or for any loss caused by the application of this product not in accordance with the current printed instructions.

Our liability is expressly limited to replacement of defective goods as per above warranty. Any claim shall be deemed waived unless made in writing to Yunca within 30 days from the date that it was or reasonably should have been discovered.

# APPENDIX D WIRING DIAGRAM

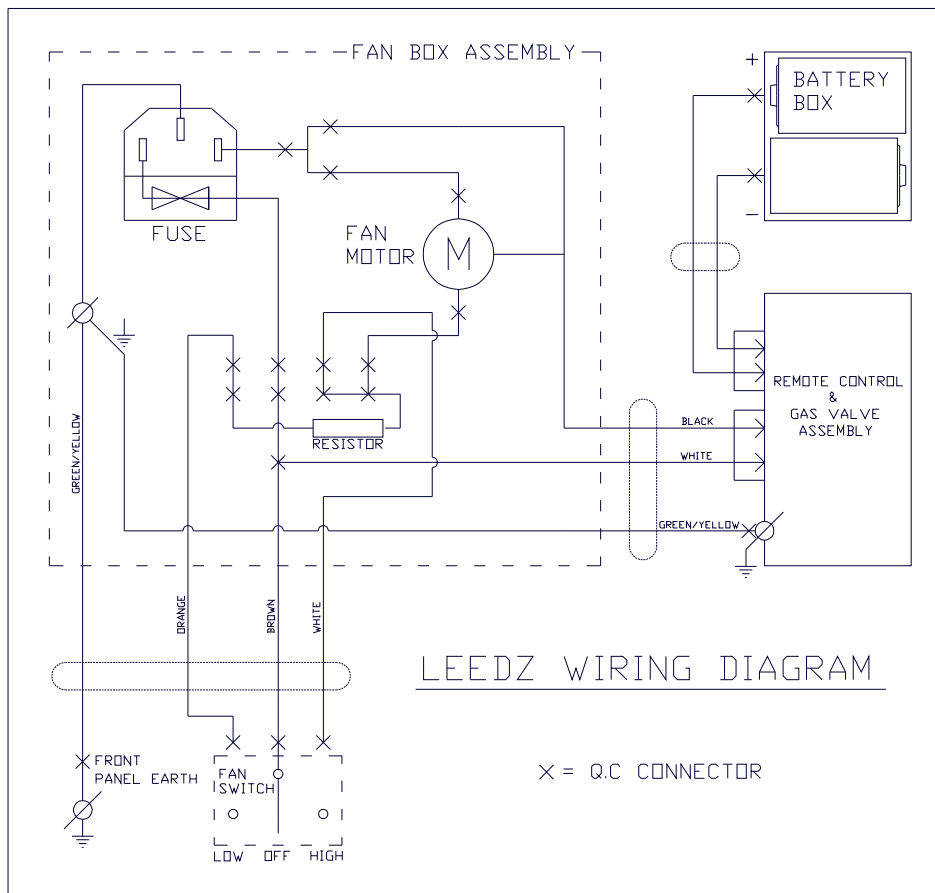

**CUSTOMER COPY** (complete and retain this section for your records)

**YUNCA LEEDZ (Fuzzy Logic control) WARRANTY REGISTRATION:**

**Serial No:** \_\_\_\_\_ **Gas Type:** \_\_\_\_\_ **Purchase Date:** \_\_\_\_\_

**Purchasers' Name:** \_\_\_\_\_

**Purchasers' Address:** \_\_\_\_\_

**City:** \_\_\_\_\_ **PostCode:** \_\_\_\_\_ **Telephone:** \_\_\_\_\_

**Where Purchased:** \_\_\_\_\_

**Installed By:** \_\_\_\_\_ **Date:** \_\_\_\_\_

Designed and Manufactured by  
Yunca Gas Dunedin  
PO Box 500  
DUNEDIN 9054  
Telephone (03) 488 4342  
Email dunedin@yunca.co.nz

✂ Cut along here-----

**This section must be completed and returned within 10 days of purchase.**

**YUNCA LEEDZ (Fuzzy Logic control) WARRANTY REGISTRATION:**

**Serial No:** \_\_\_\_\_ **Gas Type:** \_\_\_\_\_ **Purchase Date:** \_\_\_\_\_

**Purchasers' Name:** \_\_\_\_\_

**Purchasers' Address:** \_\_\_\_\_

**City:** \_\_\_\_\_ **PostCode:** \_\_\_\_\_ **Telephone:** \_\_\_\_\_

**Where Purchased:** \_\_\_\_\_

**Installed By:** \_\_\_\_\_ **Date:** \_\_\_\_\_

Return this section to: Yunca Heating  
PO Box 932  
INVERCARGILL 9840